



ATC AERO CIRCULADORES AXIALES DE AIRE LÍNEA AGROPECUARIA (GANADERÍA) TRANSMISIÓN DE POLEAS Y BANDA 24", 30", 36", 42", 48", 54", 60", 70" DE DIAMETROS

La línea AGF de Aero Circuladores de aire con transmisión de poleas y banda marca ATC ha sido especialmente diseñada para aplicaciones agropecuarias en granjas porcinas, vacunas y corrales; ATC ha combinado la ingeniería laser y robótica de punta en diseño de las hélices junto con motores de eficiencia Premium para desarrollar recirculadores económicos de alto rendimiento que mueven grandes caudales de aire a distancias largas con un mínimo de consumo de energía.

Aplicaciones:

Industria agropecuaria, granjas vacunas, porcícola, ganadera y corrales.

Características principales:

- Cuerpo, venturi y soporte del motor construido totalmente en acero galvanizado altamente resistente a la corrosión.
- Hélice fabricada en lámina galvanizada en 3 alabes en ángulo fijo aerodinámicamente balanceada diseñada para un alto flujo con un mínimo nivel sonoro.
- Accionado por transmisión de poleas y banda a los motores eléctricos monofásicos y trifásicos de 4 polos de uso continuo diseñados bajo especificaciones NEMA.
- Malla de protección galvanizada en la succión o descarga es un accesorio opcional.

ATC BELT DRIVE AXIAL AIR CIRCULATORS AGRICULTURAL SERIES (FARMS) 24", 30", 36", 42", 48", 54", 60", 70" DIAMETERS

AGF axial belt drive fan series are specially designed for agricultural industry such as livestock, farms and dairy barns. ATC has combined the precise laser and robotic engineering in design of fan blades along with the premium efficiency motors to develop the economy line of high airflow and low energy consumption fans.

Applications:

Agricultural industry, such as livestock, farms and dairy barns.

Construction features:

- Galvanized fan frame, motor and drive stands built for corrosion resistance in harsh atmosphere.
- Galvanized 3 wings aerodynamic balanced fan blade designed for high airflow and low noise level.
- 4 pole high efficiency continuous Duty single and three phase motors designed for belt drive applications.
- Optional galvanized welded wire guard on both intake and discharge.



Especificaciones Técnicas (Performance Data)

MODELO MODEL	Caudal @ DESCARGA LIBRE AIR FLOW		AMPERAJE (A) @ 60 HZ CURRENT (A) @ 60 HZ				POTENCIA POWER (HP)	RPM VENTILADOR FAN RPM	NIVEL SONORO SOUND LEVEL dB (A)*	PESO APROXIMADO APPROXIMATE WEIGHT	
			3 FASES 3 PHASE		1 FASE 1 PHASE					Lb.	Kg.
	CFM	M3/HR	230V	460V	220V	127V					
AGF-24	4,546	7,724	2.1	1.1	4.0	8.5	1/2	725	61	64	29
AGF-30	7,472	12,695	2.1	1.1	4.0	8.5	1/2	609	62	73	33
AGF-36	10,817	18,378	3.0	1.5	5.5	12.5	3/4	609	64	81	37
AGF-42	14,829	25,195	3.0	1.5	5.5	12.5	3/4	525	66	97	44
AGF-48	20,373	34,614	4.2	2.1	6.8	15.0	1	525	69	110	50
AGF-54	26,372	44,806	5.2	2.6	10.6	21.3	1 1/2	525	70	165	75
AGF-60	29,378	49,913	8.0	4.0	15.5	33.3	2	525	73	176	80
AGF-70	43,100	73,227	9.8	4.9	-	-	3	350	76	209	95

Dimensiones generales / Dimensions

Vista Frontal (Front View)

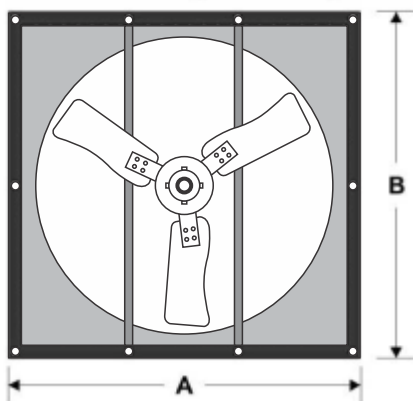

Vista Lateral (Side View)



MODELO MODEL	PULGADAS (INCHES)			Ø HÉLICE Ø FAN BLADE
	A	B	C(MAX)	
AGF-24	30	30	16	24
AGF-30	36	36	16	30
AGF-36	42	42	16	36
AGF-42	48	48	18	42
AGF-48	54	54	18	48
AGF-54	62	62	31 1/2	54
AGF-60	68	68	31 1/2	60
AGF-70	78	78	31 1/2	70

Distancia en Tiro (m) vs. Velocidad (m/s)
Throw in meters vs. Velocity in m/s

AGF -24

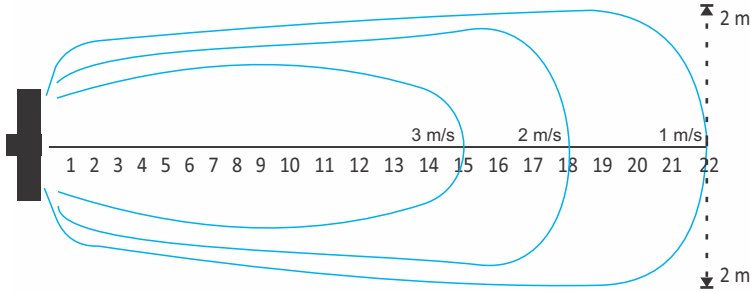

AGF -30

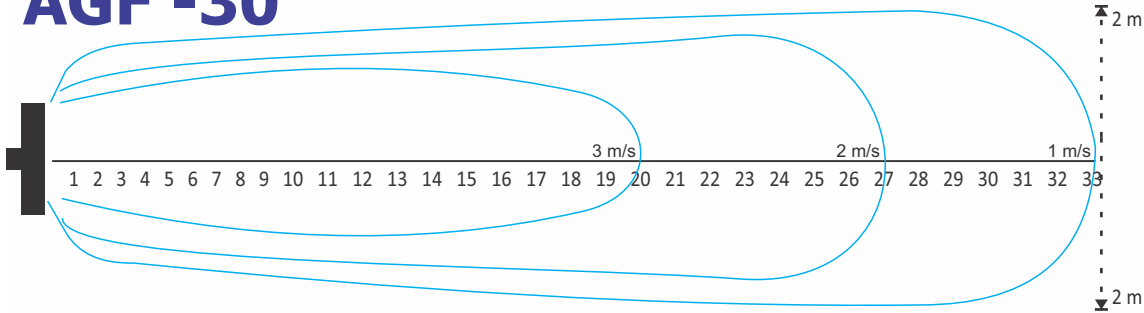

AGF -36

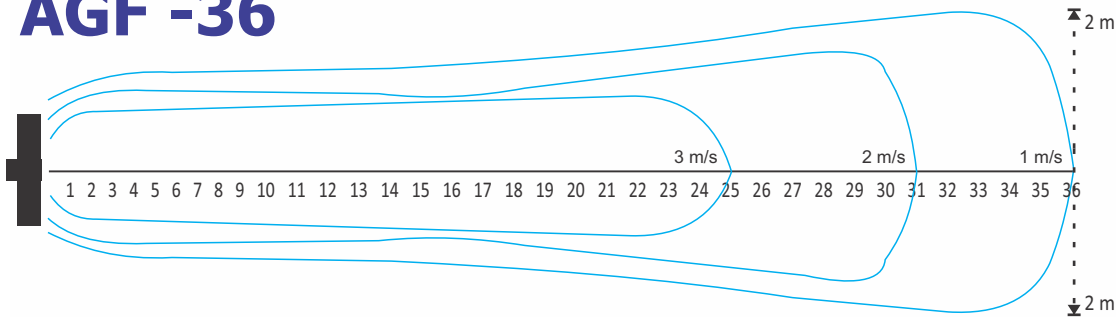

AGF -42

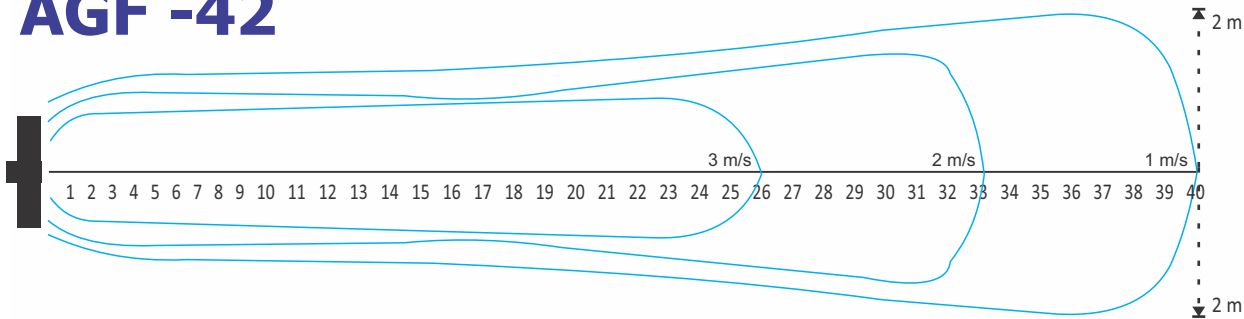

Distancia en Tiro (m) vs. Velocidad (m/s)
Throw in meters vs. Velocity in m/s

AGF -48

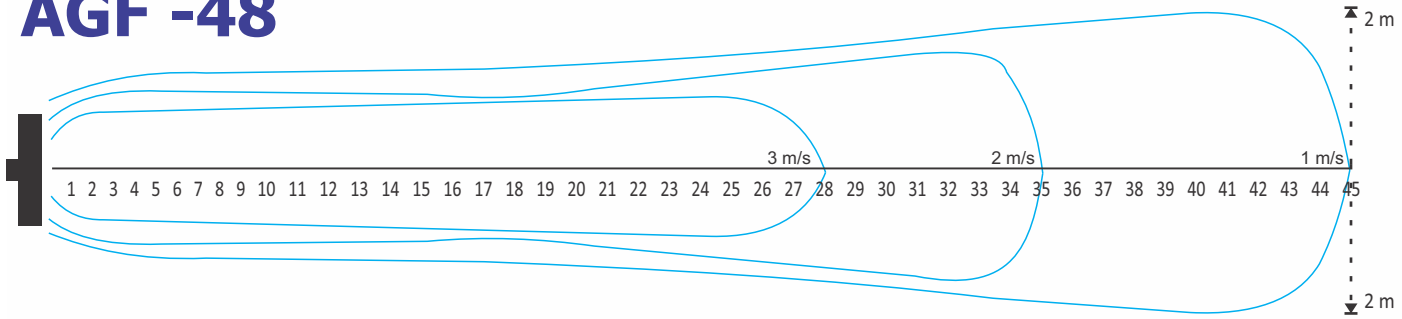

AGF -54

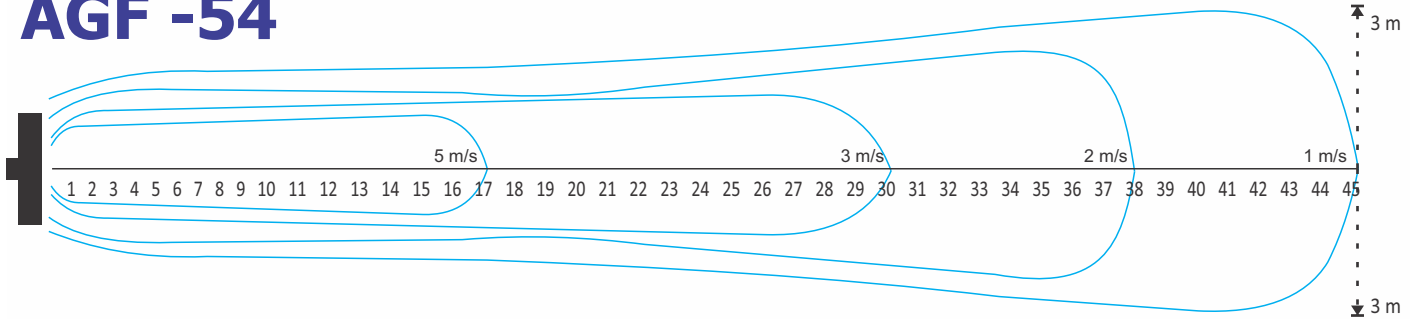

AGF -60

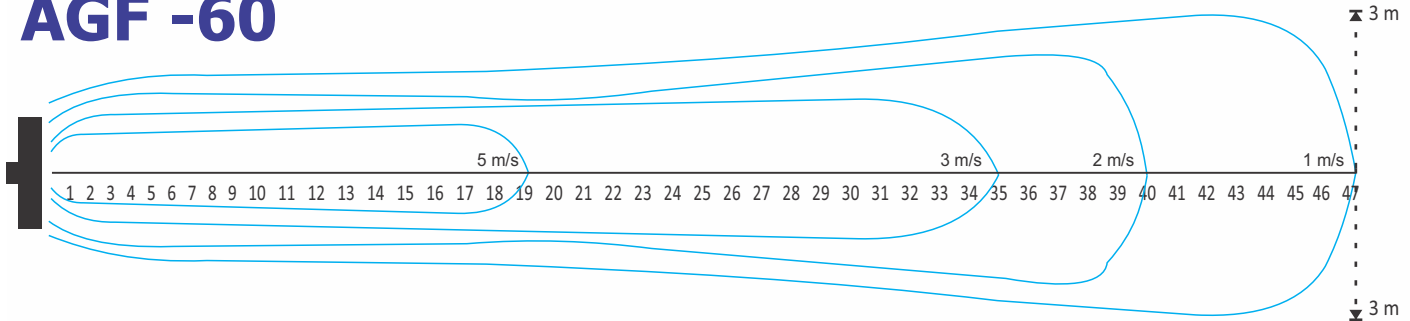

AGF -70

